

氧化锌压敏电阻器：TVR-D 系列

浪涌保护用插件型(高能系列)



■ 特点

1. 符合RoHS
2. 可提供无卤规范系列产品
3. 本体尺寸：Φ7mm ~ Φ20mm
4. 宽工作电压范围：115 Vac ~ 680 Vac
5. 最大通流等级可达13KA
6. 最大能量等级可达720焦耳
7. 工作温度范围：-40°C ~ +85°C
储存温度范围：-40°C ~ +125°C
8. 安规认证：UL 1449 3rd / cUL / VDE / CQC
9. TVR10-D、14-D、20-D符合IEC 60950-1:2013, Annex Q要求
10. TVR20-D 系列可选择适用于UL 1449 3rd SPD Type 2应用

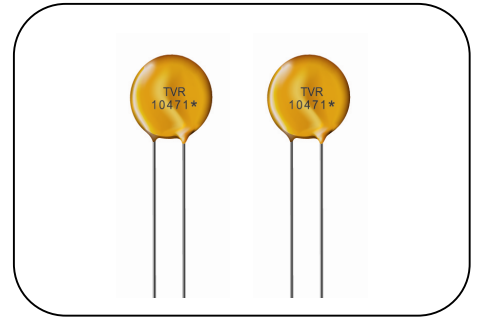

备注：产品型号后面打印一码 * 代表为 TVR-D 系列

■ 用途

1. 电源供应器
2. 家用电器
3. 工业设备
4. 通信设备
5. 智能控制型电表
6. 电力线智能通讯设备
7. 照明
8. 光伏系统

■ 编码规则

Φ 7mm ~ Φ 20mm

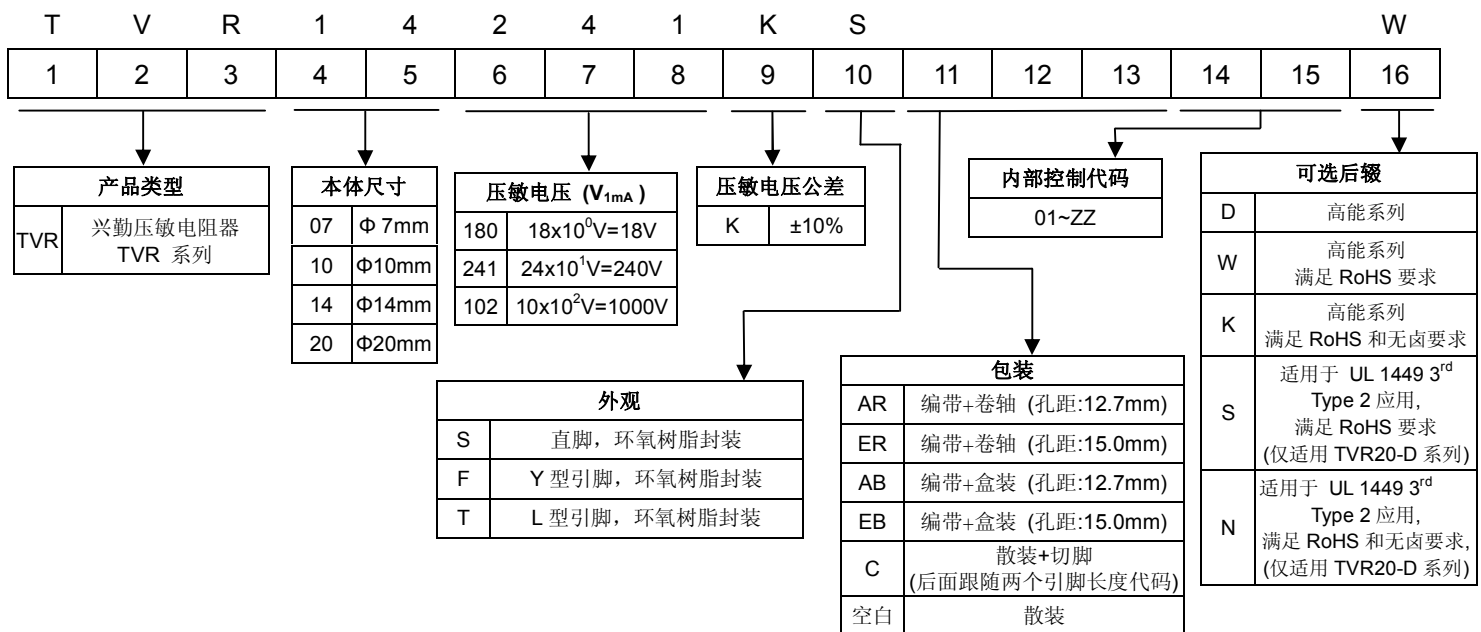

备注：包装及内部控制代码未使用时，第 11 码为可选后缀。

氧化锌压敏电阻器：TVR-D 系列

浪涌保护用插件型(高能系列)



■ 结构与尺寸

● S 型 (直脚)

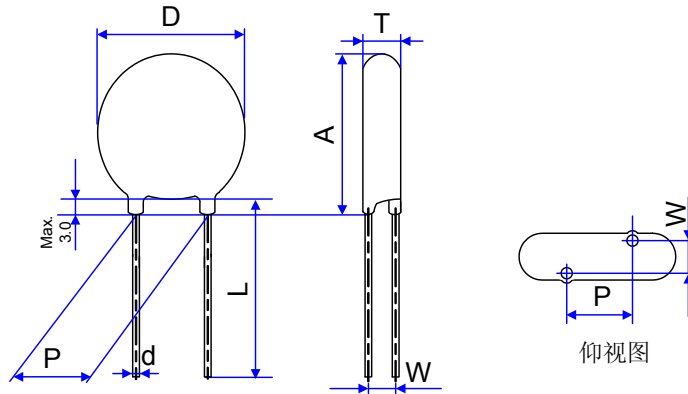

(单位：mm)

系列	D	Lmin.	d	P	Amax.	Tmax.	W
TVR07-D	7.5~9.5	26.5	0.6±0.02	5±1	12.5	请见电气特性表	
TVR10-D	12.0~14.0	26.5	0.8±0.02	7.5±1	17.5		
TVR14-D	16.0~18.5	26.5	0.8±0.02	7.5±1	21.5		
TVR20-D	22~24.5	22.5	1.0±0.02	10±1	28.5		

● F 型 (Y型引脚)

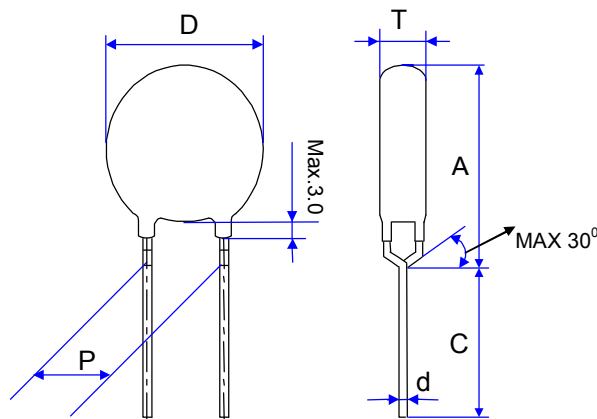

(单位：mm)

系列	D	Cmin.	d	P	Amax.	Tmax.	W
TVR07-D	7.5~9.5	20	0.6±0.02	5±1	12.5	请见电气特性表	
TVR10-D	12.0~14.0	20	0.8±0.02	7.5±1	18.0		
TVR14-D	16.0~18.5	20	0.8±0.02	7.5±1	22.0		
TVR20-D	22~24.5	20	1.0±0.02	10±1	29.0		

氧化锌压敏电阻器：TVR-D 系列

浪涌保护用插件型(高能系列)



● T 型 (L型引脚)

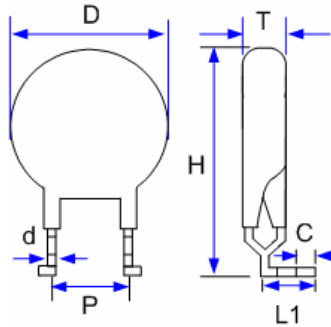

(单位：mm)

系列	D	C	d	P	Hmax.	L1	Tmax.
TVR10-D	12.0~14.0	3.8±0.8	0.8±0.02	7.5±1	22.0	7.0±1	请见电气特性表
TVR14-D	16.0~18.5		0.8±0.02	7.5±1	26.5	7.0±1	
TVR20-D	22.0~24.5		1.0±0.02	10±1	33.0	9.0±1	

氧化锌压敏电阻器：TVR-D 系列

浪涌保护用插件型(高能系列)



■ 电气特性

07-D系列

安规型号	料号	压敏电压 (@ 1mA DC)	最大连续 工作电压		最大 限制电压 (8/20 μ s)		最大 冲击电流 (8/20 μ s)	额定 功率	最大能量 (10/1000 μ s)	参考电容 @1KHz	产品尺寸			UL 1449 3 rd SPD 应用类型
		V _{1mA}	V _{AC(rms)}	V _{DC}	V _P	I _P	I _{max}	P	W _{max}	C _p	T _{min}	T _{max}	W ± 1.0	
		(V)	(V)	(V)	(V)	(A)	(A)	(W)	(J)	(pF)	(mm)			
TVR07181-D	TVR07181KSW	180 (162~198)	115	150	300	10	1800	0.25	19	255	2.0	3.9	1.4	适用于其 它应用
TVR07201-D	TVR07201KSW	200 (180~220)	130	170	340	10	1800	0.25	21	230	2.1	4.0	1.5	
TVR07221-D	TVR07221KSW	220 (198~242)	140	180	360	10	1800	0.25	23	210	2.1	4.0	1.5	
TVR07241-D	TVR07241KSW	240 (216~264)	150	200	395	10	1800	0.25	25	195	2.3	4.2	1.6	
TVR07271-D	TVR07271KSW	270 (243~297)	175	225	455	10	1800	0.25	28	175	2.4	4.4	1.7	
TVR07301-D	TVR07301KSW	300 (270~330)	195	250	500	10	1800	0.25	32	155	2.7	4.4	1.9	
TVR07331-D	TVR07331KSW	330 (297~363)	215	275	550	10	1800	0.25	34	140	2.8	4.5	2.0	
TVR07361-D	TVR07361KSW	360 (324~396)	230	300	595	10	1800	0.25	37	130	2.9	4.6	2.1	
TVR07391-D	TVR07391KSW	390 (351~429)	250	320	650	10	1800	0.25	40	120	3.1	4.8	2.3	
TVR07431-D	TVR07431KSW	430 (387~473)	275	350	710	10	1800	0.25	46	100	3.0	5.1	2.3	
TVR07471-D	TVR07471KSW	470 (423~517)	300	385	775	10	1800	0.25	49	90	3.2	5.2	2.4	
TVR07511-D	TVR07511KSW	510 (459~561)	320	410	845	10	1800	0.25	54	85	3.4	5.4	2.6	
TVR07561-D	TVR07561KSW	560 (504~616)	350	450	930	10	1800	0.25	55	80	3.6	5.5	2.8	
TVR07621-D	TVR07621KSW	620 (558~682)	395	510	1020	10	1800	0.25	59	80	3.9	5.9	3.0	
TVR07681-D	TVR07681KSW	680 (612~748)	420	560	1120	10	1800	0.25	62	75	4.1	6.2	3.2	
TVR07751-D	TVR07751KSW	750 (675~825)	465	615	1235	10	1800	0.25	66	70	4.4	6.4	3.5	
TVR07821-D	TVR07821KSW	820 (738~902)	510	670	1355	10	1800	0.25	71	65	4.5	6.4	3.2	

氧化锌压敏电阻器：TVR-D 系列

浪涌保护用插件型(高能系列)



10-D系列

安规型号	料号	压敏电压 (@ 1mA DC)	最大连续 工作电压		最大 限制电压 (8/20μs)		最大 冲击电流 (8/20μs)	额定 功率	最大能量 (10/1000μs)	参考电容 @1KHz	产品尺寸			UL 1449 3 rd SPD 应用类型
		V _{1mA}	V _{AC(rms)}	V _{DC}	V _P	I _P	I _{max}	P	W _{max}	C _p	T _{min}	T _{max}	W ±1.0	
		(V)	(V)	(V)	(V)	(A)	(A)	(W)	(J)	(pF)	(mm)			
TVR10181-D	TVR10181KSW	180 (162~198)	115	150	300	25	4000	0.4	47	570	2.4	4.3	1.6	适用于其 它应用
TVR10201-D	TVR10201KSW	200 (180~220)	130	170	340	25	4000	0.4	52	520	2.5	4.4	1.7	适用于 SPD Type 3 应用
TVR10221-D	TVR10221KSW	220 (198~242)	140	180	360	25	4000	0.4	58	470	2.5	4.4	1.7	
TVR10241-D	TVR10241KSW	240 (216~264)	150	200	395	25	4000	0.4	64	420	2.7	4.6	1.8	
TVR10271-D	TVR10271KSW	270 (243~297)	175	225	455	25	4000	0.4	67	370	2.8	4.8	1.9	
TVR10301-D	TVR10301KSW	300 (270~330)	195	250	500	25	4000	0.4	70	340	3.1	4.8	2.1	
TVR10331-D	TVR10331KSW	330 (297~363)	215	275	550	25	4000	0.4	72	320	3.2	4.9	2.2	
TVR10361-D	TVR10361KSW	360 (324~396)	230	300	595	25	4000	0.4	76	300	3.3	5.0	2.3	
TVR10391-D	TVR10391KSW	390 (351~429)	250	320	650	25	4000	0.4	82	280	3.5	5.2	2.5	
TVR10431-D	TVR10431KSW	430 (387~473)	275	350	710	25	4000	0.4	93	250	3.4	5.5	2.5	
TVR10471-D	TVR10471KSW	470 (423~517)	300	385	775	25	4000	0.4	99	240	3.6	5.6	2.6	
TVR10511-D	TVR10511KSW	510 (459~561)	320	410	845	25	4000	0.4	107	220	3.8	5.8	2.8	
TVR10561-D	TVR10561KSW	560 (504~616)	350	450	930	25	4000	0.4	113	200	4.0	5.9	3.0	
TVR10621-D	TVR10621KSW	620 (558~682)	395	510	1020	25	4000	0.4	125	190	4.3	6.3	3.2	
TVR10681-D	TVR10681KSW	680 (612~748)	420	560	1120	25	4000	0.4	128	180	4.9	6.6	3.4	
TVR10751-D	TVR10751KSW	750 (675~825)	465	615	1235	25	4000	0.4	134	170	4.9	6.8	3.7	
TVR10821-D	TVR10821KSW	820 (738~902)	510	670	1355	25	4000	0.4	146	140	4.9	6.8	3.4	
TVR10911-D	TVR10911KSW	910 (819~1001)	550	745	1500	25	4000	0.4	152	130	5.3	7.2	3.7	
TVR10102-D	TVR10102KSW	1000(900~1100)	625	825	1650	25	4000	0.4	170	120	5.5	7.5	4.0	
TVR10112-D	TVR10112KSW	1100(990~1210)	680	895	1815	25	4000	0.4	180	110	5.7	8.0	4.3	

氧化锌压敏电阻器：TVR-D 系列

浪涌保护用插件型(高能系列)



14-D系列

安规型号	料号	压敏电压 (@ 1mA DC)	最大连续 工作电压		最大 限制电压 (8/20μs)		最大 冲击电流 (8/20μs)	额定 功率	最大能量 (10/1000μs)	参考电容 @1KHz	产品尺寸			UL 1449 3 rd SPD 应用类型
		V _{1mA}	V _{AC(rms)}	V _{DC}	V _P	I _P	I _{max}	P	W _{max}	C _p	T _{min}	T _{max}	W ±1.0	
		(V)	(V)	(V)	(V)	(A)	(A)	(W)	(J)	(pF)	(mm)			
TVR14181-D	TVR14181KSW	180 (162~198)	115	150	300	50	8000	0.6	60	1000	2.4	4.3	1.6	适用于 SPD Type 3 应用
TVR14201-D	TVR14201KSW	200 (180~220)	130	170	340	50	8000	0.6	82	900	2.5	4.4	1.7	
TVR14221-D	TVR14221KSW	220 (198~242)	140	180	360	50	8000	0.6	90	850	2.5	4.4	1.7	
TVR14241-D	TVR14241KSW	240 (216~264)	150	200	395	50	8000	0.6	98	780	2.7	4.6	1.8	
TVR14271-D	TVR14271KSW	270 (243~297)	175	225	455	50	8000	0.6	116	650	2.8	4.8	1.9	
TVR14301-D	TVR14301KSW	300 (270~330)	195	250	500	50	8000	0.6	128	610	3.1	4.8	2.1	
TVR14331-D	TVR14331KSW	330 (297~363)	215	275	550	50	8000	0.6	140	580	3.2	4.9	2.2	
TVR14361-D	TVR14361KSW	360 (324~396)	230	300	595	50	8000	0.6	158	550	3.3	5.0	2.3	
TVR14391-D	TVR14391KSW	390 (351~429)	250	320	650	50	8000	0.6	170	520	3.5	5.2	2.5	
TVR14431-D	TVR14431KSW	430 (387~473)	275	350	710	50	8000	0.6	185	480	3.4	5.5	2.5	
TVR14471-D	TVR14471KSW	470 (423~517)	300	385	775	50	8000	0.6	205	460	3.6	5.6	2.6	
TVR14511-D	TVR14511KSW	510 (459~561)	320	410	845	50	8000	0.6	220	430	3.8	5.8	2.8	
TVR14561-D	TVR14561KSW	560 (504~616)	350	450	930	50	8000	0.6	240	390	4.0	5.9	3.0	
TVR14621-D	TVR14621KSW	620 (558~682)	395	510	1020	50	8000	0.6	250	350	4.3	6.3	3.2	
TVR14681-D	TVR14681KSW	680 (612~748)	420	560	1120	50	8000	0.6	260	320	4.5	6.6	3.4	
TVR14751-D	TVR14751KSW	750 (675~825)	465	615	1235	50	8000	0.6	270	290	4.8	6.8	3.7	
TVR14821-D	TVR14821KSW	820 (738~902)	510	670	1355	50	8000	0.6	280	250	4.9	6.8	3.4	
TVR14911-D	TVR14911KSW	910 (819~1001)	550	745	1500	50	8000	0.6	295	230	5.3	7.2	3.7	
TVR14102-D	TVR14102KSW	1000(900~1100)	625	825	1650	50	8000	0.6	335	210	5.7	7.5	4.0	
TVR14112-D	TVR14112KSW	1100(990~1210)	680	895	1815	50	8000	0.6	360	190	5.8	8.0	4.3	

氧化锌压敏电阻器：TVR-D 系列

浪涌保护用插件型(高能系列)



20-D系列

安规型号	料号	压敏电压 (@ 1mA DC)	最大连续 工作电压			最大 限制电压 (8/20μs)		最大 冲击电流 (8/20μs)	额定 功率	最大能量 (10/1000μs)	参考电容 @1KHz	产品尺寸			UL 1449 3 rd SPD 应用类型
		V _{1mA}	V _{AC(rms)}	V _{DC}	V _P	I _P	I _{max}	P	W _{max}	C _p	T _{min}	T _{max}	W ±1.0		
		(V)	(V)	(V)	(V)	(A)	(A)	(W)	(J)	(pF)	(mm)				
TVR20181-D	TVR20181KSW	180 (162~198)	115	150	300	100	13000	1.0	152	2200	2.8	4.7	1.8	适用于 SPD Type 3 应用	
TVR20201-D	TVR20201KSW	200 (180~220)	130	170	340	100	13000	1.0	175	1900	2.9	4.8	1.9		
TVR20221-D	TVR20221KSW	220 (198~242)	140	180	360	100	13000	1.0	185	1700	2.9	4.8	1.9		
TVR20241-D	TVR20241KSW	240 (216~264)	150	200	395	100	13000	1.0	198	1500	3.1	5.0	2.0		
TVR20271-D	TVR20271KSW	270 (243~297)	175	225	455	100	13000	1.0	220	1400	3.2	5.2	2.1		
TVR20301-D	TVR20301KSW	300 (270~330)	195	250	500	100	13000	1.0	245	1300	3.5	5.2	2.3		
TVR20331-D	TVR20331KSW	330 (297~363)	215	275	550	100	13000	1.0	268	1200	3.6	5.3	2.4		
TVR20361-D	TVR20361KSW	360 (324~396)	230	300	595	100	13000	1.0	315	1000	3.7	5.4	2.5		
TVR20391-D	TVR20391KSW	390 (351~429)	250	320	650	100	13000	1.0	350	880	3.9	5.6	2.7		
TVR20431-D	TVR20431KSW	430 (387~473)	275	350	710	100	13000	1.0	380	800	3.8	5.9	2.7		
TVR20471-D	TVR20471KSW	470 (423~517)	300	385	775	100	13000	1.0	405	700	4.0	6.0	2.8		
TVR20511-D	TVR20511KSW	510 (459~561)	320	410	845	100	13000	1.0	445	630	4.2	6.2	3.0		
TVR20561-D	TVR20561KSW	560 (504~616)	350	450	930	100	13000	1.0	475	530	4.4	6.3	3.2		
TVR20621-D	TVR20621KSW	620 (558~682)	395	510	1020	100	13000	1.0	490	490	4.7	6.7	3.4		
TVR20681-D	TVR20681KSW	680 (612~748)	420	560	1120	100	13000	1.0	500	470	4.9	7.0	3.6		
TVR20751-D	TVR20751KSW	750 (675~825)	465	615	1235	100	13000	1.0	525	450	5.2	7.2	3.9		
TVR20821-D	TVR20821KSW	820 (738~902)	510	670	1355	100	13000	1.0	545	410	5.3	7.2	3.6		
TVR20911-D	TVR20911KSW	910 (819~1001)	550	745	1500	100	13000	1.0	595	380	5.7	7.6	3.9		
TVR20102-D	TVR20102KSW	1000(900~1100)	625	825	1650	100	13000	1.0	650	360	6.1	7.9	4.2		
TVR20112-D	TVR20112KSW	1100(990~1210)	680	895	1815	100	13000	1.0	720	340	6.2	8.4	4.5		

氧化锌压敏电阻器：TVR-D 系列

浪涌保护用插件型(高能系列)



适用于SPD Type 2的20-D系列

安规型号	料号	压敏电压 (@ 1mA DC)	最大连续 工作电压			最大 限制电压 (8/20 μ s)		最大 冲击电流 (8/20 μ s)	标称 放电电流 ^{*1} (8/20 μ s)	额定 功率	最大能量 (10/1000 μ s)	参考 电容 @1KHz	产品尺寸			UL 1449 3 rd SPD 应用类型
		V _{1mA}	V _{AC(rms)}	V _{DC}	V _P	I _P	I _{max}	I _n	P	W _{max}	C _p	T _{min}	T _{max}	W \pm 1.0		
		(V)	(V)	(V)	(V)	(A)	(A)	(A)	(W)	(J)	(pF)	(mm)				
TVR20181-S	TVR20181KSS	180 (162~198)	115	150	300	100	13000	5000	1.0	152	2200	2.8	4.7	1.8	适用于 SPD Type 2 应用	
TVR20201-S	TVR20201KSS	200 (180~220)	130	170	340	100	13000	5000	1.0	175	1900	2.9	4.8	1.9		
TVR20221-S	TVR20221KSS	220 (198~242)	140	180	360	100	13000	5000	1.0	185	1700	2.9	4.8	1.9		
TVR20241-S	TVR20241KSS	240 (216~264)	150	200	395	100	13000	5000	1.0	198	1500	3.1	5.0	2.0		
TVR20271-S	TVR20271KSS	270 (243~297)	175	225	455	100	13000	5000	1.0	220	1400	3.2	5.2	2.1		
TVR20301-S	TVR20301KSS	300 (270~330)	195	250	500	100	13000	5000	1.0	245	1300	3.5	5.2	2.3		
TVR20331-S	TVR20331KSS	330 (297~363)	215	275	550	100	13000	5000	1.0	268	1200	3.6	5.3	2.4		
TVR20361-S	TVR20361KSS	360 (324~396)	230	300	595	100	13000	5000	1.0	315	1000	3.7	5.4	2.5		
TVR20391-S	TVR20391KSS	390 (351~429)	250	320	650	100	13000	5000	1.0	350	880	3.9	5.6	2.7		
TVR20431-S	TVR20431KSS	430 (387~473)	275	350	710	100	13000	5000	1.0	380	800	3.8	5.9	2.7		
TVR20471-S	TVR20471KSS	470 (423~517)	300	385	775	100	13000	5000	1.0	405	700	4.0	6.0	2.8		
TVR20511-S	TVR20511KSS	510 (459~561)	320	410	845	100	13000	5000	1.0	445	630	4.2	6.2	3.0		
TVR20561-S	TVR20561KSS	560 (504~616)	350	450	930	100	13000	5000	1.0	475	530	4.4	6.3	3.2		
TVR20621-S	TVR20621KSS	620 (558~682)	395	510	1020	100	13000	5000	1.0	490	490	4.7	6.7	3.4		
TVR20681-S	TVR20681KSS	680 (612~748)	420	560	1120	100	13000	5000	1.0	500	470	4.9	7.0	3.6		
TVR20751-S	TVR20751KSS	750 (675~825)	465	615	1235	100	13000	5000	1.0	525	450	5.2	7.2	3.9		
TVR20821-S	TVR20821KSS	820 (738~902)	510	670	1355	100	13000	5000	1.0	545	410	5.3	7.2	3.6		
TVR20911-S	TVR20911KSS	910 (819~1001)	550	745	1500	100	13000	5000	1.0	595	380	5.7	7.6	3.9		
TVR20102-S	TVR20102KSS	1000(900~1100)	625	825	1650	100	13000	5000	1.0	650	360	6.1	7.9	4.2		
TVR20112-S	TVR20112KSS	1100(990~1210)	680	895	1815	100	13000	5000	1.0	720	340	6.2	8.4	4.5		

备注：



*1：标称放电电流(Nominal discharge current)为UL1449第三版里规范使用8/20 μ s电流波定义之参数。

氧化锌压敏电阻器：TVR-D 系列

浪涌保护用插件型(高能系列)



■ 安规认证

安规认证型号	认证机构				
					
	UL1449 3 rd & cUL : E314979	40021243	IEC60950-1:2013 Annex Q	GB/T10193-1997 GB/T10194-1997 CQC10001041750 CQC10001041751	GB8898-2011 GB4943.1-2011 CQC10001041750 CQC10001041751
TVR07181-D	√	√		√	
TVR07201-D	√	√		√	
TVR07221-D	√	√		√	
TVR07241-D	√	√		√	
TVR07271-D	√	√		√	
TVR07301-D	√	√		√	
TVR07331-D	√	√		√	
TVR07361-D	√	√		√	
TVR07391-D	√	√		√	
TVR07431-D	√	√		√	
TVR07471-D	√	√		√	
TVR07511-D	√	√		√	
TVR07561-D	√	√		√	
TVR07621-D	√	√		√	
TVR07681-D	√	√		√	
TVR07751-D	√	√		√	
TVR07821-D	√	√		√	
TVR10181-D	√	√	√	√	
TVR10201-D	√	√	√	√	√
TVR10221-D	√	√	√	√	√
TVR10241-D	√	√	√	√	√
TVR10271-D	√	√	√	√	√
TVR10301-D	√	√	√	√	√
TVR10331-D	√	√	√	√	√
TVR10361-D	√	√	√	√	√
TVR10391-D	√	√	√	√	√
TVR10431-D	√	√	√	√	√
TVR10471-D	√	√	√	√	√
TVR10511-D	√	√	√	√	√
TVR10561-D	√	√	√	√	√
TVR10621-D	√	√	√	√	√
TVR10681-D	√	√	√	√	√
TVR10751-D	√	√	√	√	√
TVR10821-D	√	√	√	√	√
TVR10911-D	√	√	√	√	√
TVR10102-D	√	√	√	√	√
TVR10112-D	√	√	√	√	√

氧化锌压敏电阻器：TVR-D 系列

浪涌保护用插件型(高能系列)



安规认证型号	认证机构				
	UL1449 3 rd & cUL : E314979	40021243	IEC60950-1:2013 Annex Q	GB/T10193-1997 GB/T10194-1997 CQC10001041750 CQC10001041751	GB8898-2011 GB4943.1-2011 CQC10001041750 CQC10001041751
TVR14181-D	√	√	√	√	
TVR14201-D	√	√	√	√	√
TVR14221-D	√	√	√	√	√
TVR14241-D	√	√	√	√	√
TVR14271-D	√	√	√	√	√
TVR14301-D	√	√	√	√	√
TVR14331-D	√	√	√	√	√
TVR14361-D	√	√	√	√	√
TVR14391-D	√	√	√	√	√
TVR14431-D	√	√	√	√	√
TVR14471-D	√	√	√	√	√
TVR14511-D	√	√	√	√	√
TVR14561-D	√	√	√	√	√
TVR14621-D	√	√	√	√	√
TVR14681-D	√	√	√	√	√
TVR14751-D	√	√	√	√	√
TVR14821-D	√	√	√	√	√
TVR14911-D	√	√	√	√	√
TVR14102-D	√	√	√	√	√
TVR14112-D	√	√	√	√	√
TVR20181-D / -S	√	√	√	√	
TVR20201-D / -S	√	√	√	√	√
TVR20221-D / -S	√	√	√	√	√
TVR20241-D / -S	√	√	√	√	√
TVR20271-D / -S	√	√	√	√	√
TVR20301-D / -S	√	√	√	√	√
TVR20331-D / -S	√	√	√	√	√
TVR20361-D / -S	√	√	√	√	√
TVR20391-D / -S	√	√	√	√	√
TVR20431-D / -S	√	√	√	√	√
TVR20471-D / -S	√	√	√	√	√
TVR20511-D / -S	√	√	√	√	√
TVR20561-D / -S	√	√	√	√	√
TVR20621-D / -S	√	√	√	√	√
TVR20681-D / -S	√	√	√	√	√
TVR20751-D / -S	√	√	√	√	√
TVR20821-D / -S	√	√	√	√	√
TVR20911-D / -S	√	√	√	√	√
TVR20102-D / -S	√	√	√	√	√
TVR20112-D / -S	√	√	√	√	√

氧化锌压敏电阻器：TVR-D 系列

浪涌保护用插件型(高能系列)



功率减额曲线

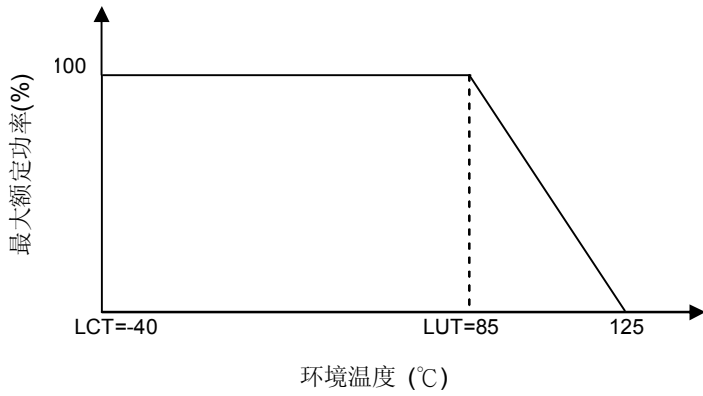

冲击电流标准波形

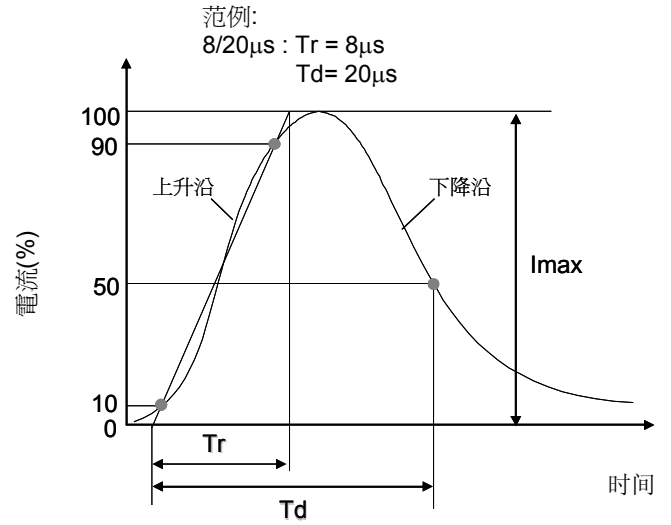

最大冲击电流减额曲线

TVR07181-D to TVR07471-D

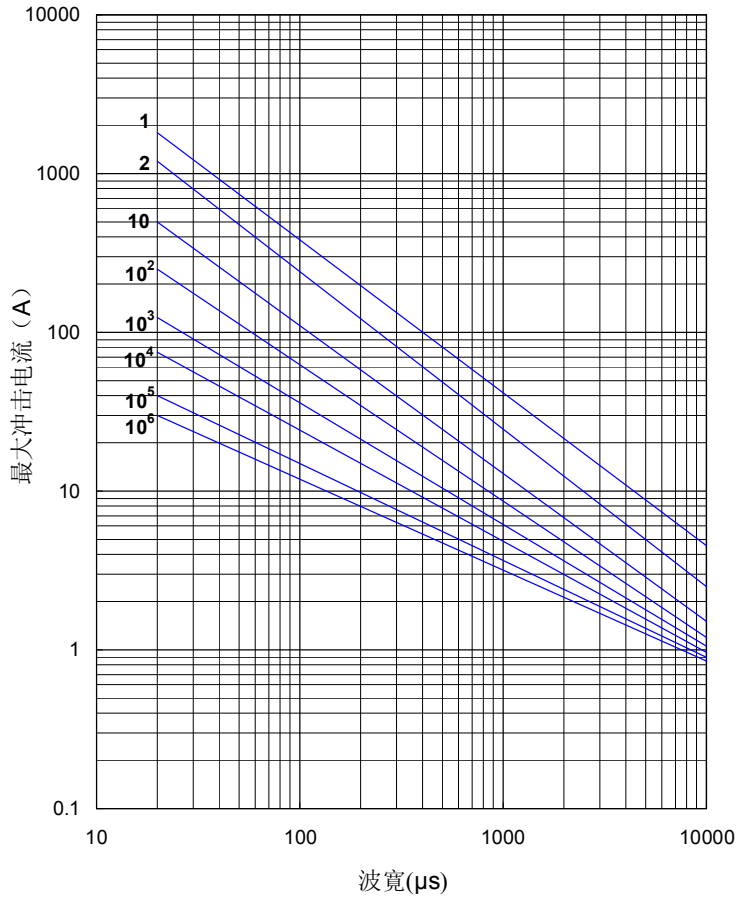

TVR07511-D to TVR07821-D

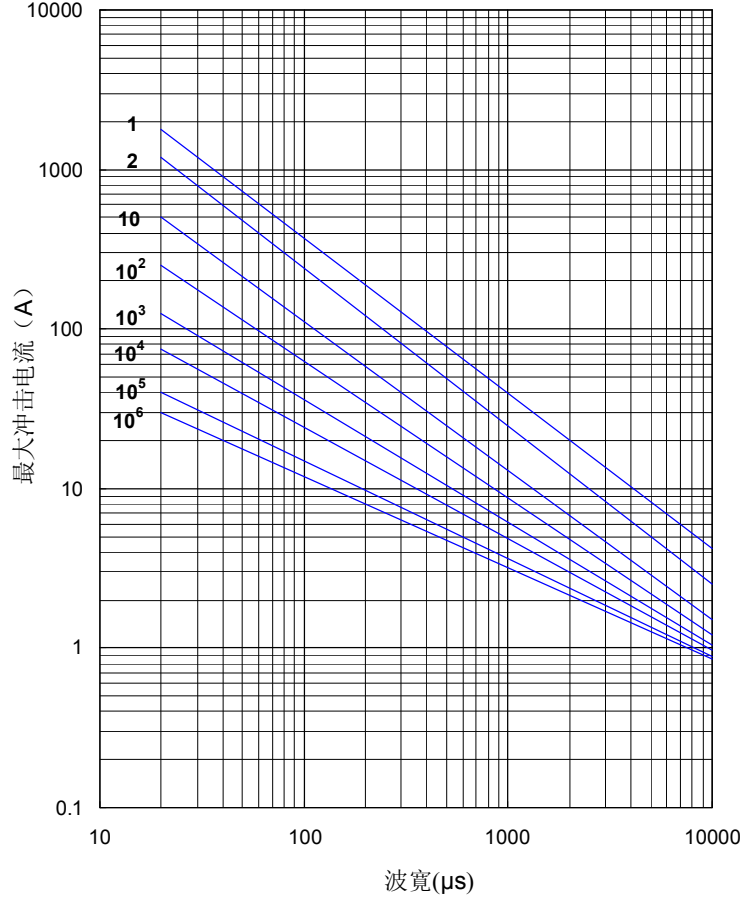

氧化锌压敏电阻：TVR-D 系列

浪涌保护用插件型(高能系列)



最大冲击电流减额曲线

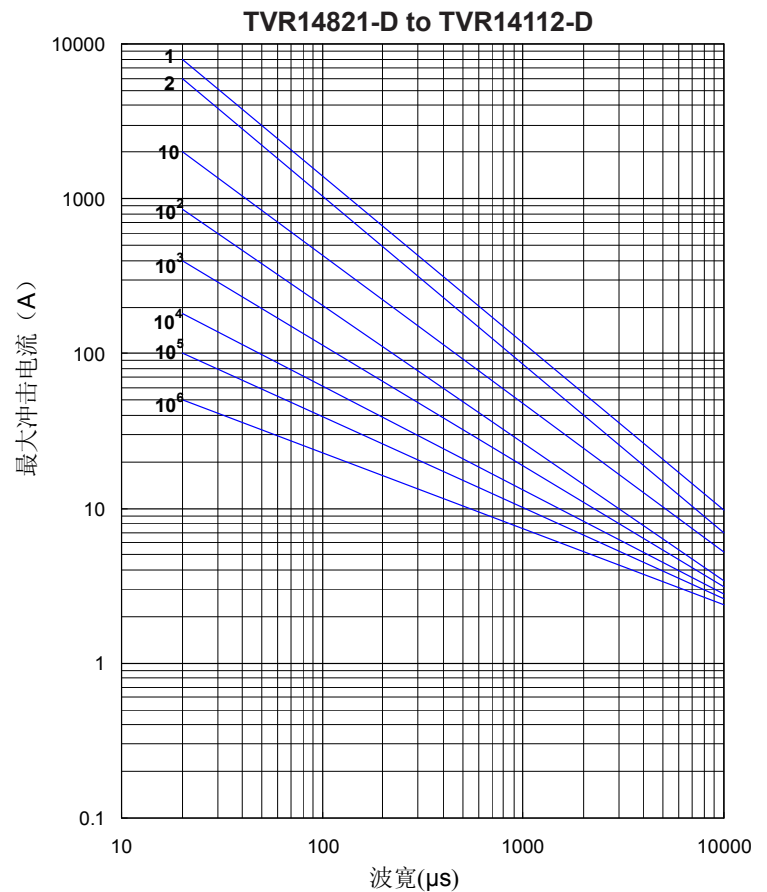
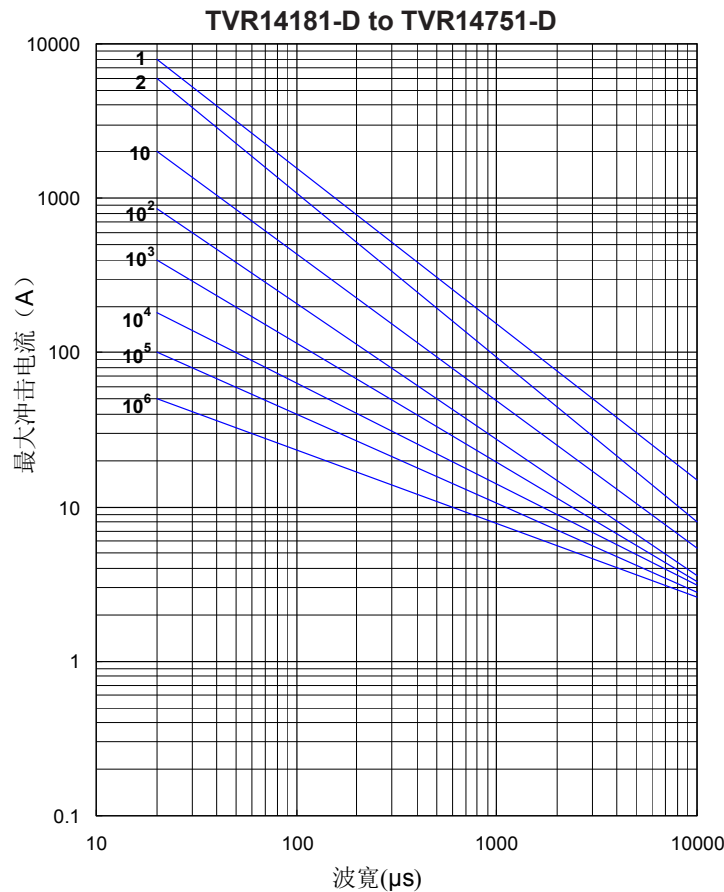
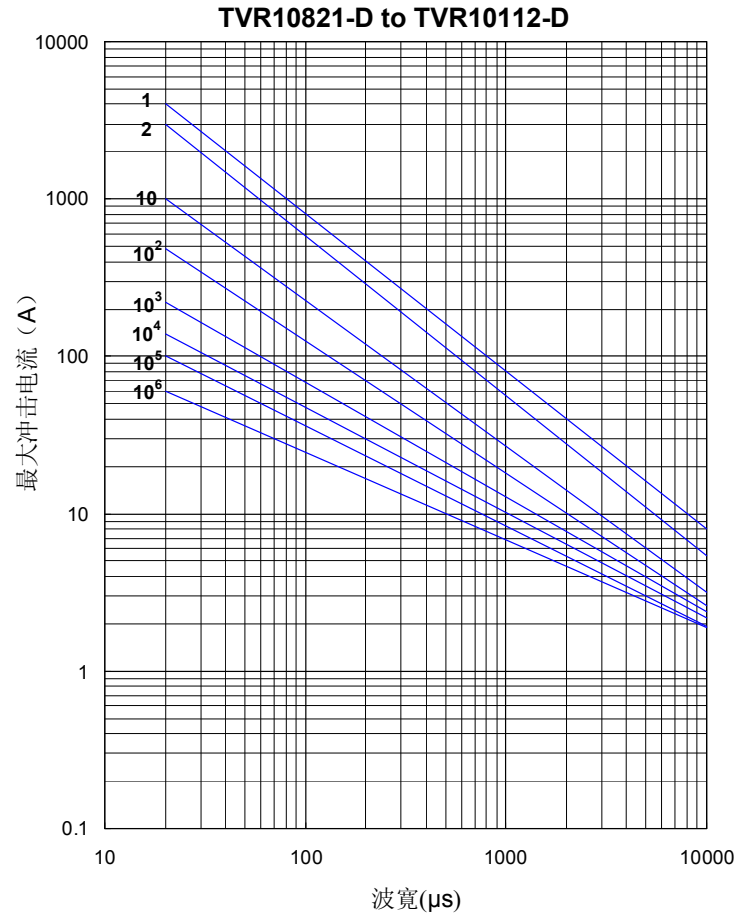
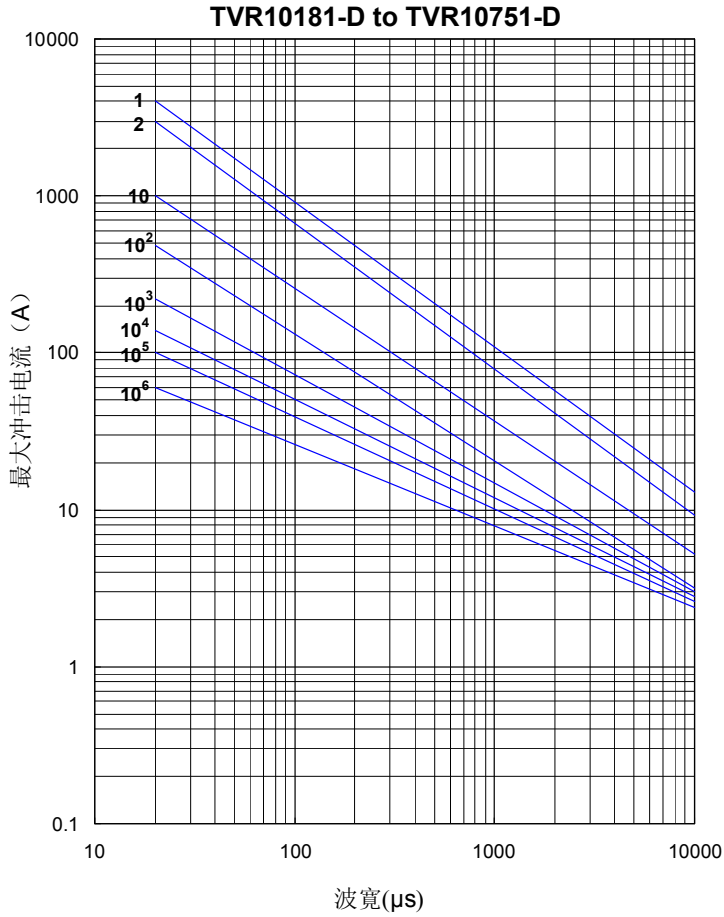

氧化锌压敏电阻：TVR-D 系列

浪涌保护用插件型(高能系列)



最大冲击电流减额曲线

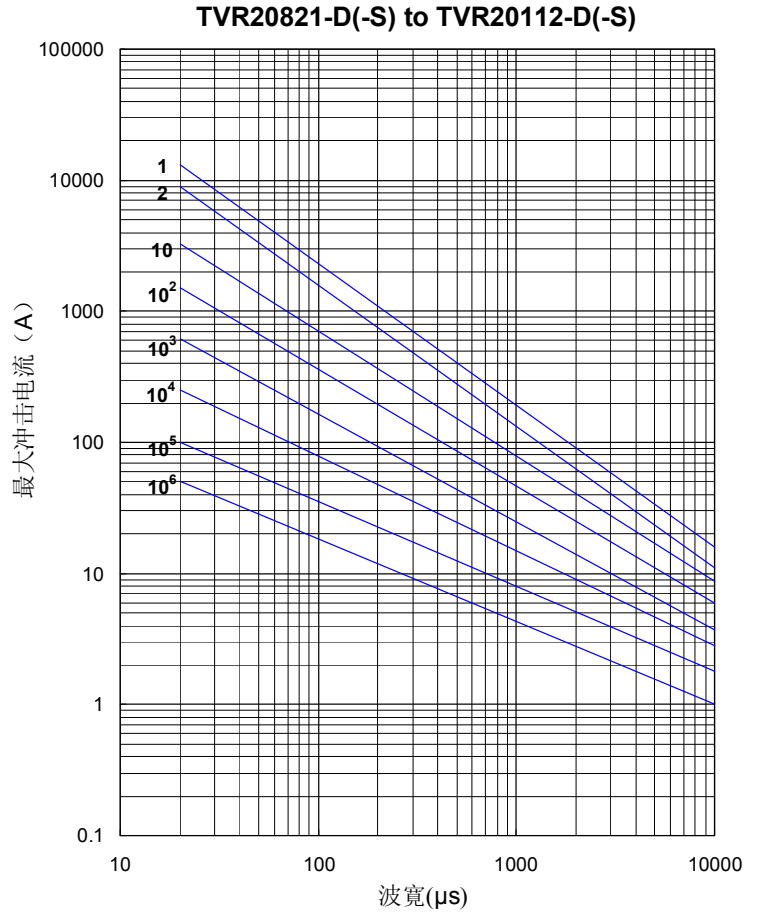
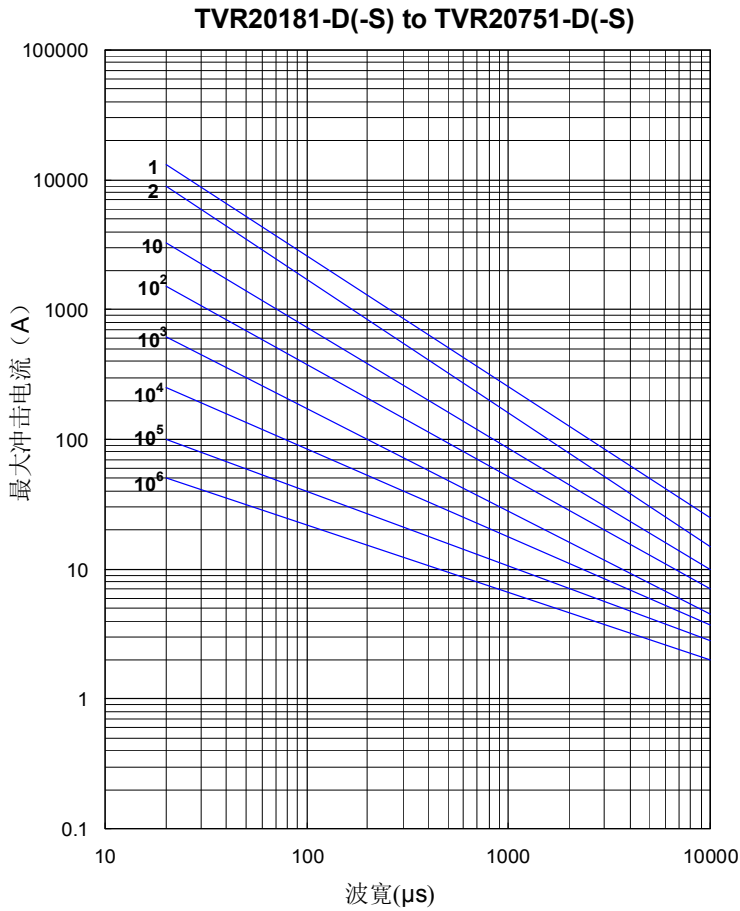

最大漏电流与最大限制电压曲线

最大漏电流与最大限制电压曲线 (TVR07181-D to TVR07471-D)

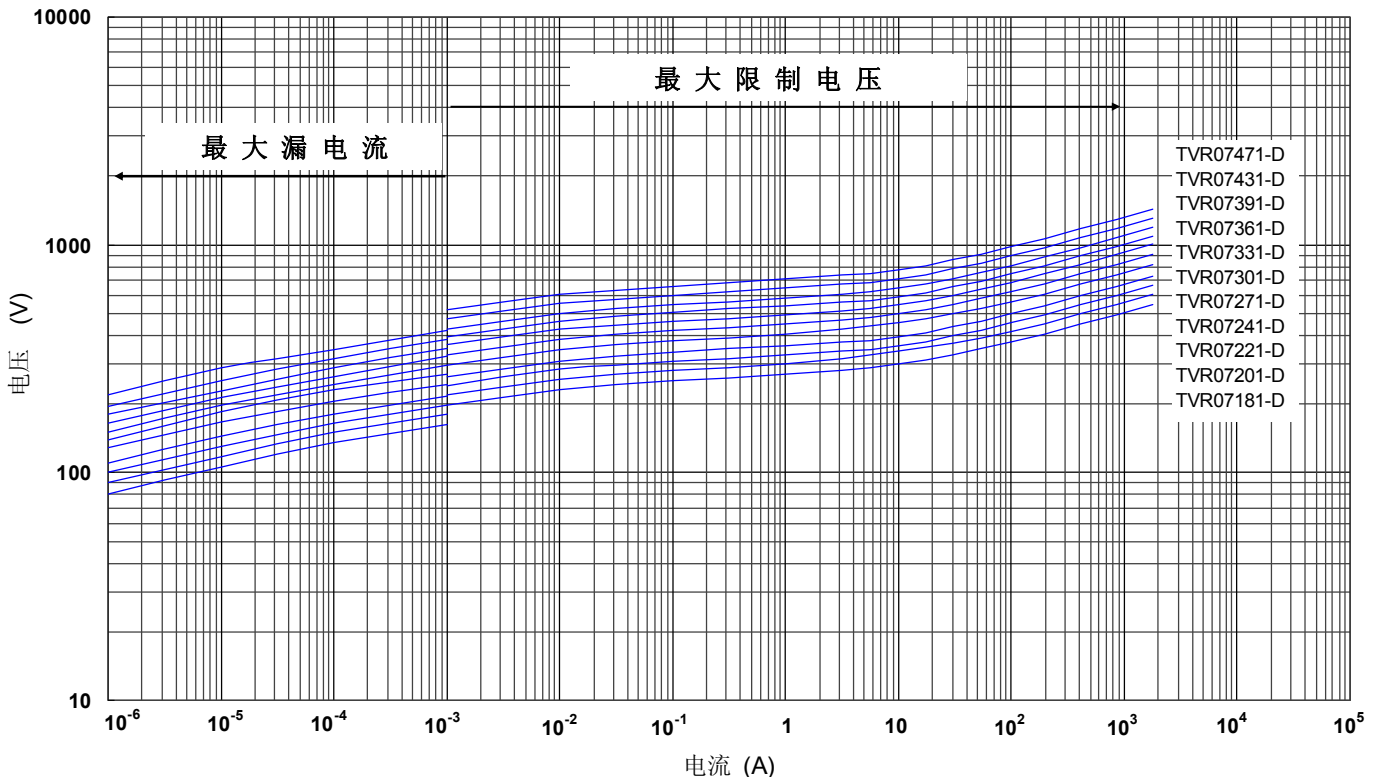

氧化锌压敏电阻器：TVR-D 系列

浪涌保护用插件型(高能系列)



最大漏电流与最大限制电压曲线

最大漏电流与最大限制电压曲线 (TVR07511-D to TVR07821-D)

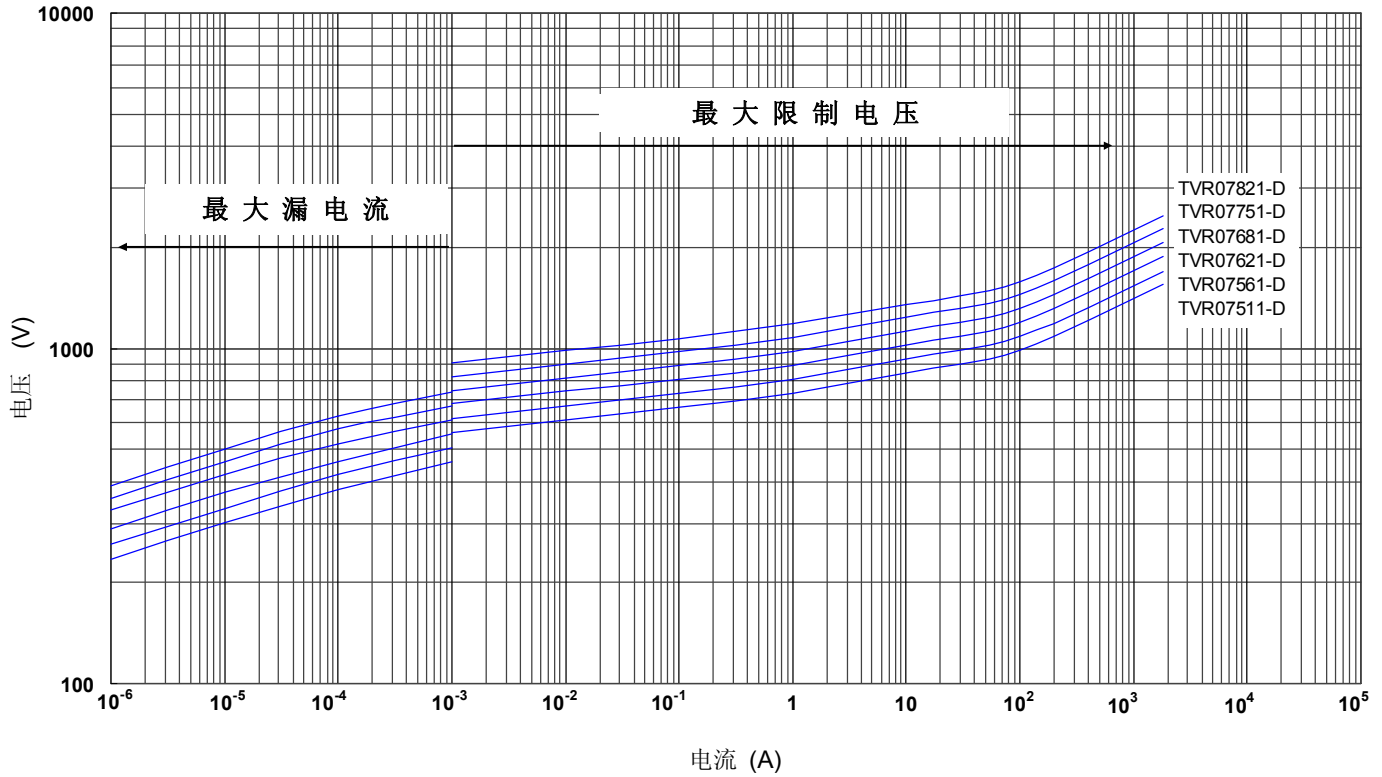

最大漏电流与最大限制电压曲线 (TVR10181-D to TVR10471-D)

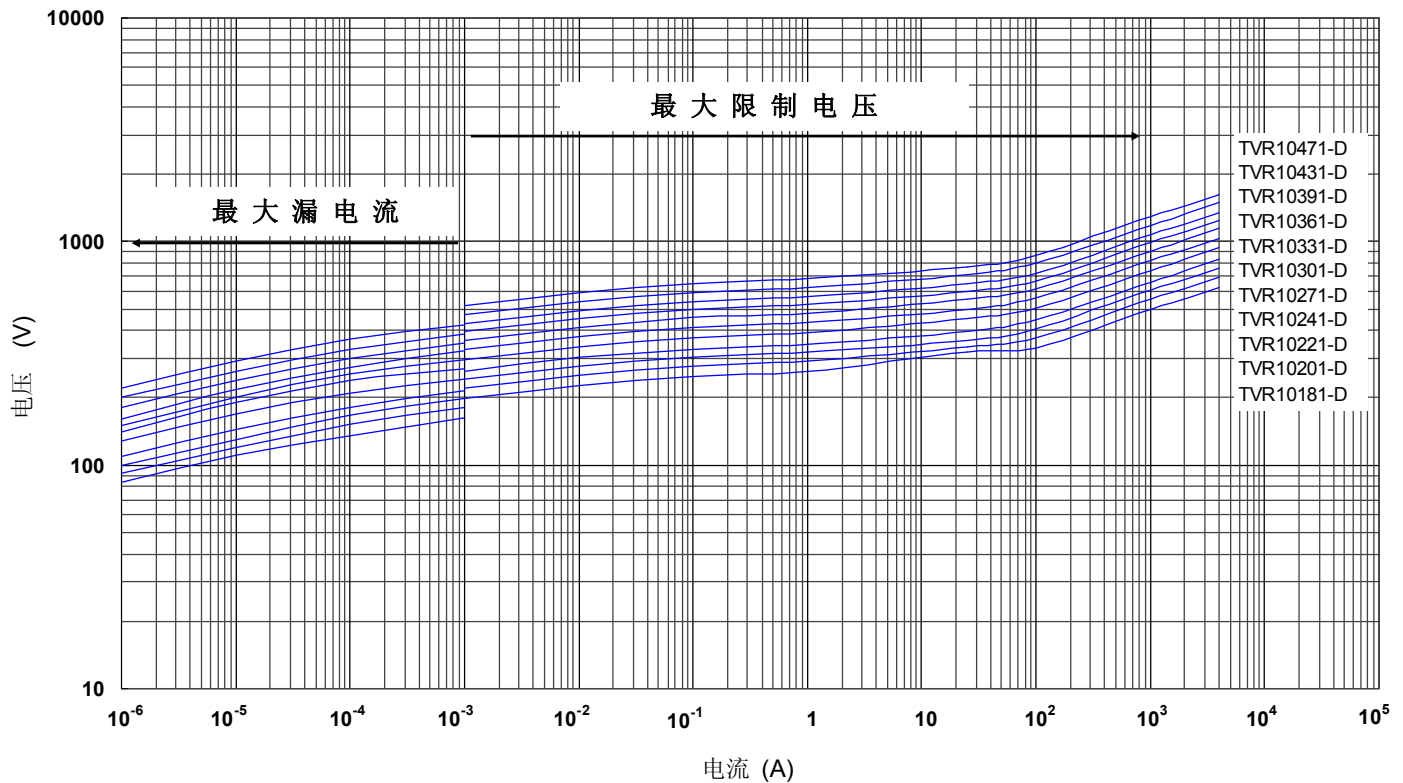

氧化锌压敏电阻器：TVR-D 系列

浪涌保护用插件型(高能系列)



最大漏电流与最大限制电压曲线

最大漏电流与最大限制电压曲线 (TVR10511-D to TVR10112-D)

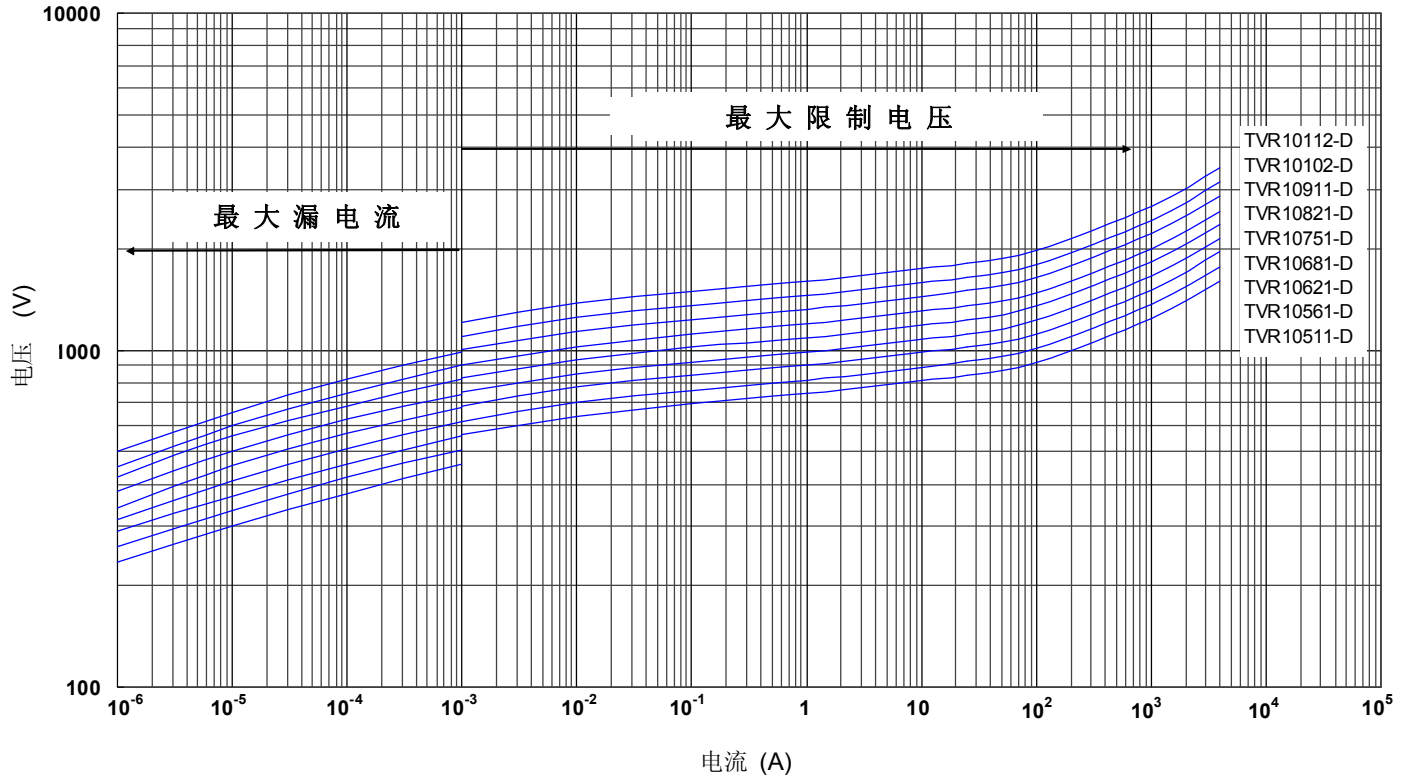

最大漏电流与最大限制电压曲线 (TVR14181-D to TVR14471-D)

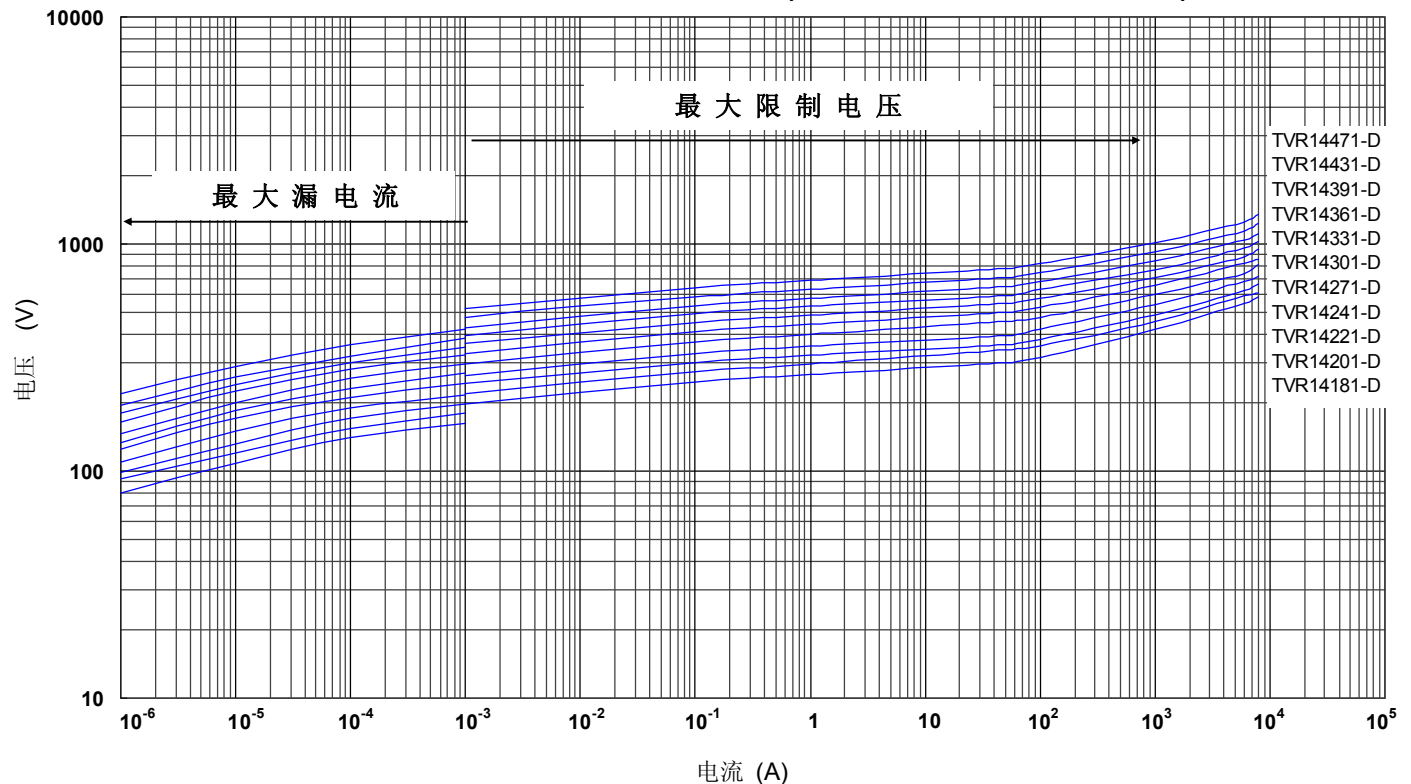

氧化锌压敏电阻器：TVR-D 系列

浪涌保护用插件型(高能系列)



最大漏电流与最大限制电压曲线

最大漏电流与最大限制电压曲线 (TVR14511-D to TVR14112-D)

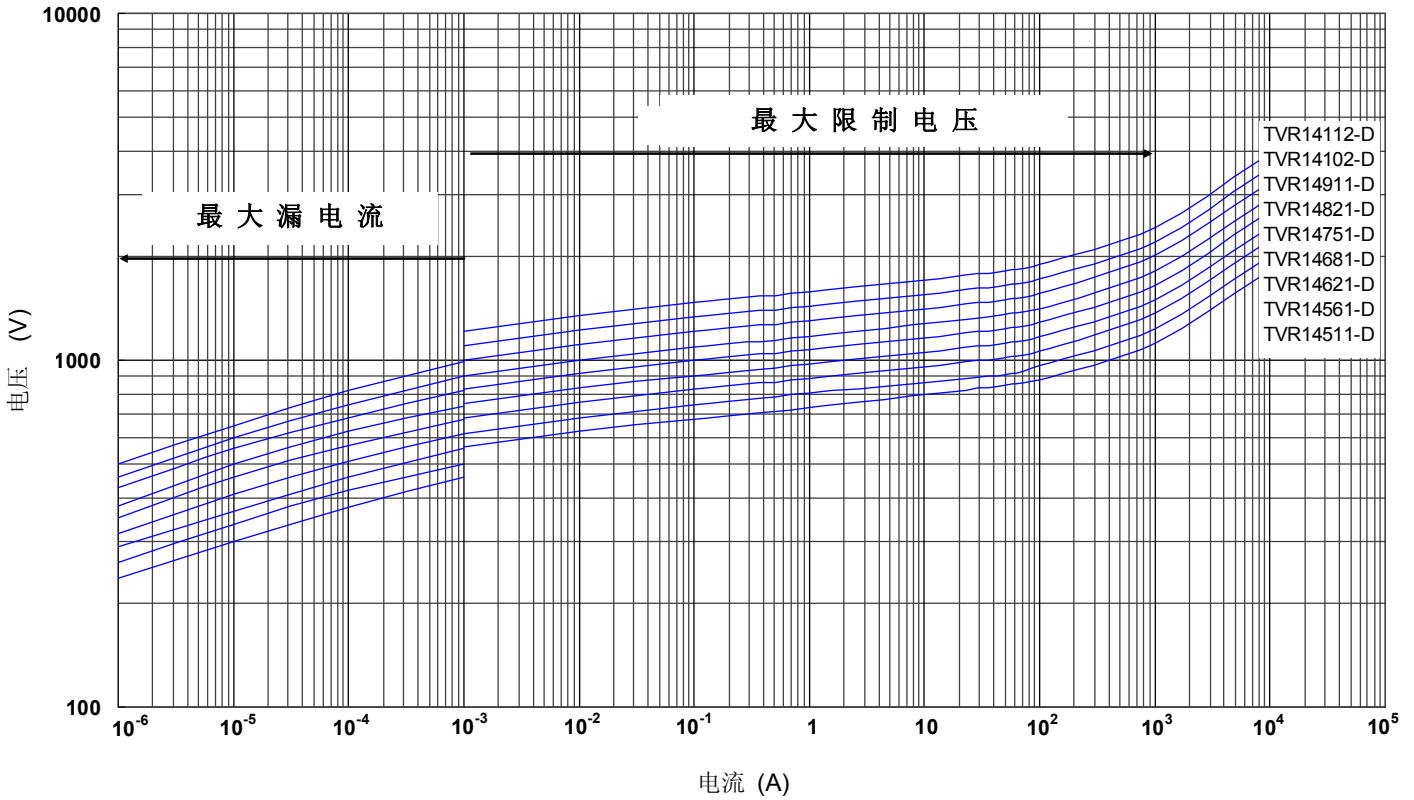

最大漏电流与最大限制电压曲线 (TVR20181-D(-S) to TVR20471-D(-S))

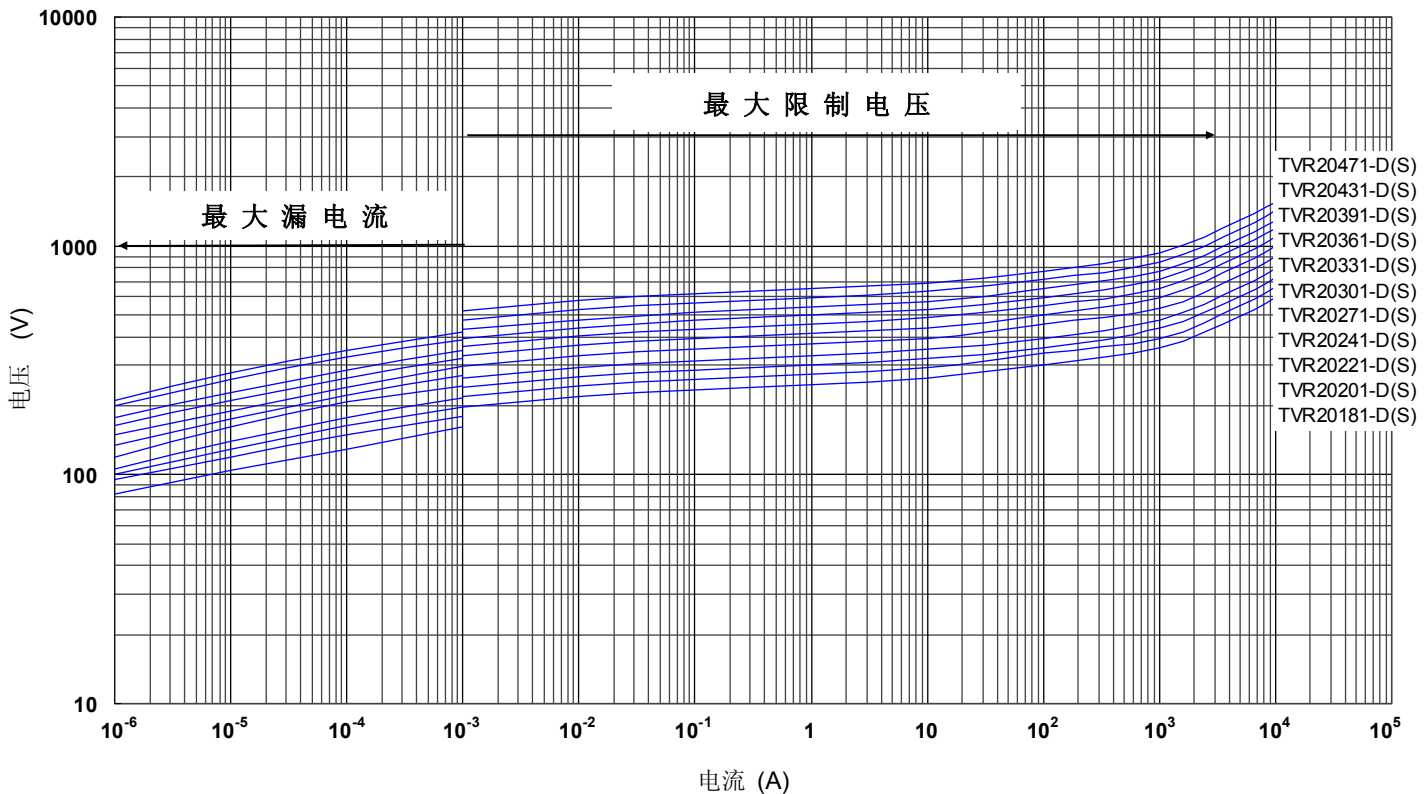

氧化锌压敏电阻器：TVR-D 系列

浪涌保护用插件型(高能系列)



最大漏电流与最大限制电压曲线

最大漏电流与最大限制电压曲线 (TVR20511-D(-S) to TVR20112-D(-S))

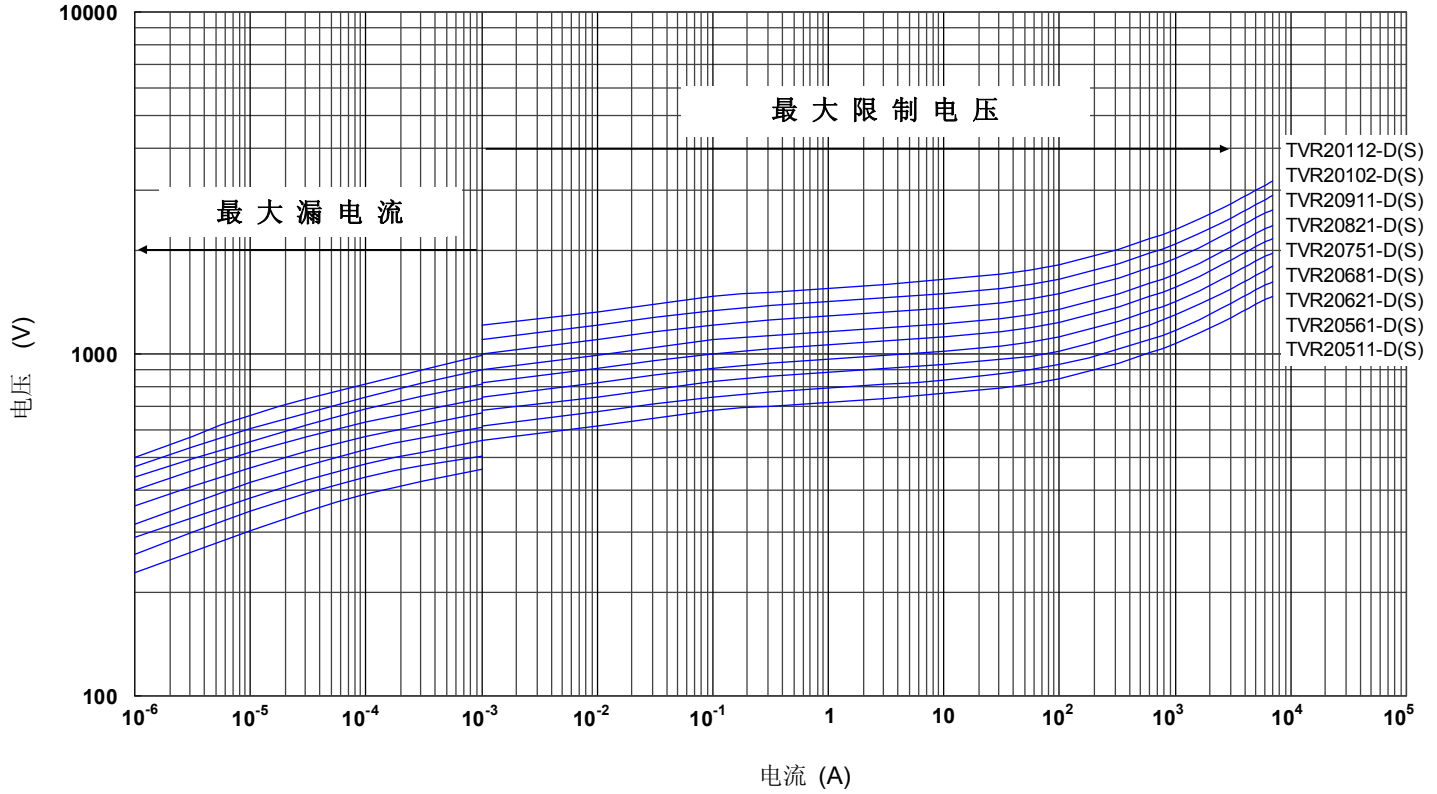

氧化锌压敏电阻器：TVR-D 系列

浪涌保护用插件型(高能系列)



■ 推荐焊接条件

● 波峰焊曲线

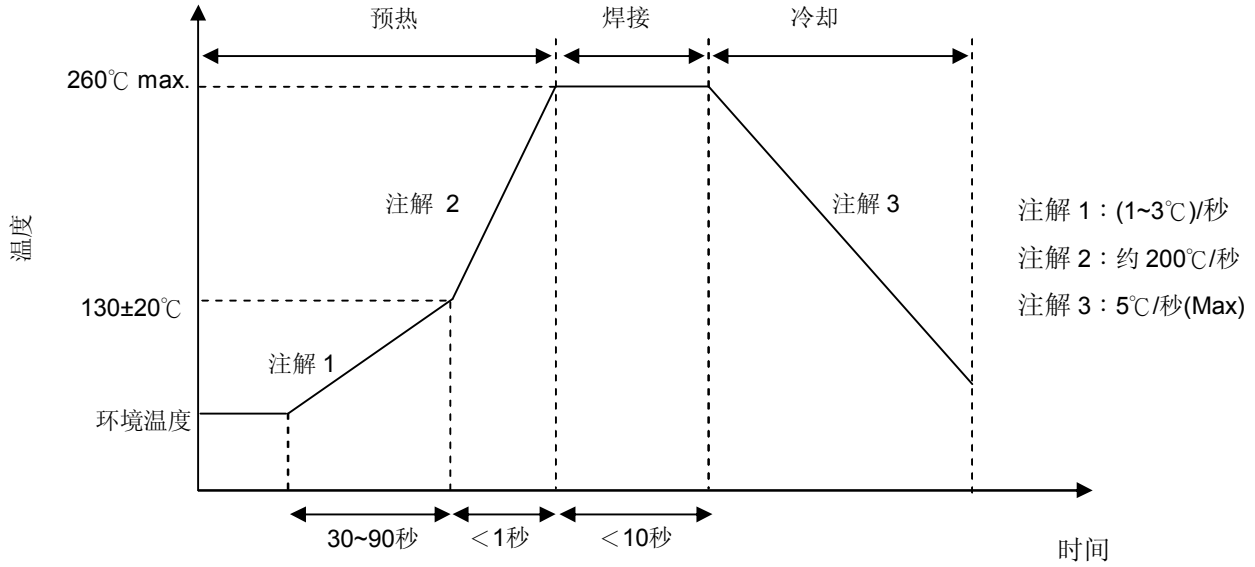

● 烙铁重工焊接条件

项目	条件
烙铁头部温度	360°C (max.)
焊接时间	3 sec (max.)
焊接位置与涂装层的距离	2 mm (min.)

氧化锌压敏电阻器：TVR-D 系列

浪涌保护用插件型(高能系列)



■ 可靠性

试验项目	测试标准	试验条件/方法	性能要求															
引线拉力试验	IEC 60068-2-21	<p>渐近的方式施加指定的重量，并且在固定位置维持 10±1 秒。</p> <table border="1"> <tr> <td>线径 (mm)</td> <td>引线直接下拉力 (Kg)</td> </tr> <tr> <td>0.5<d≤0.8</td> <td>1.0</td> </tr> <tr> <td>0.8<d≤1.25</td> <td>2.0</td> </tr> </table>	线径 (mm)	引线直接下拉力 (Kg)	0.5<d≤0.8	1.0	0.8<d≤1.25	2.0	$ \Delta V_{1mA} / V_{1mA} \leq 5\%$ 无外观损伤									
线径 (mm)	引线直接下拉力 (Kg)																	
0.5<d≤0.8	1.0																	
0.8<d≤1.25	2.0																	
引线弯折试验	IEC 60068-2-21	<p>对样品的一条引线加指定的重量，先向原方向弯折 90°，再复原到原位。然后反向弯折 90°，以相同方法进行。</p> <table border="1"> <tr> <td>线径 (mm)</td> <td>弯折试验加力 (Kg)</td> </tr> <tr> <td>0.5<d≤0.8</td> <td>0.5</td> </tr> <tr> <td>0.8<d≤1.25</td> <td>1.0</td> </tr> </table>	线径 (mm)	弯折试验加力 (Kg)	0.5<d≤0.8	0.5	0.8<d≤1.25	1.0	$ \Delta V_{1mA} / V_{1mA} \leq 5\%$ 无外观损伤									
线径 (mm)	弯折试验加力 (Kg)																	
0.5<d≤0.8	0.5																	
0.8<d≤1.25	1.0																	
振荡试验	IEC 60068-2-6	频率范围：10 ~ 55 Hz 振幅：0.75mm 或 98 m/s ² 持续时间：6 小时 (3 x 2 小时)	$ \Delta V_{1mA} / V_{1mA} \leq 5\%$ 无外观损伤															
可焊性试验	IEC 60068-2-20	245±5℃，3±0.3 秒	着锡面积≥95%															
耐焊接热试验	IEC 60068-2-20	260±3℃，10±1 秒	$ \Delta V_{1mA} / V_{1mA} \leq 5\%$ 无外观损伤															
高温存储试验	IEC 60068-2-2	125±5℃ x 1000 小时±24 小时	$ \Delta V_{1mA} / V_{1mA} \leq 5\%$ 无外观损伤															
稳态湿热试验	IEC 60068-2-78	试验分 a、b 两组： a. 40±2℃，90 ~ 95 % RH，1344 小时 b. 40±2℃，90 ~ 95 % RH，10% V _{DC} ，1344 小时	$ \Delta V_{1mA} / V_{1mA} \leq 5\%$ 无外观损伤 绝缘阻抗≥100MΩ															
温度急变试验	IEC 60068-2-14	温度急变按下表条件循环五个周期。 <table border="1"> <thead> <tr> <th>步骤</th> <th>温度 (°C)</th> <th>时间 (分钟)</th> </tr> </thead> <tbody> <tr> <td>1</td> <td>-40±3</td> <td>30±3</td> </tr> <tr> <td>2</td> <td>室温</td> <td>5±3</td> </tr> <tr> <td>3</td> <td>85±2</td> <td>30±3</td> </tr> <tr> <td>4</td> <td>室温</td> <td>5±3</td> </tr> </tbody> </table>	步骤	温度 (°C)	时间 (分钟)	1	-40±3	30±3	2	室温	5±3	3	85±2	30±3	4	室温	5±3	$ \Delta V_{1mA} / V_{1mA} \leq 5\%$ 无外观损伤
步骤	温度 (°C)	时间 (分钟)																
1	-40±3	30±3																
2	室温	5±3																
3	85±2	30±3																
4	室温	5±3																
高温负荷试验	MIL-STD-202 Method 108	85 ± 2 °C，1000 ± 24 小时，施加 V _{DC} 或 V _{rms} (最大连续工作电压)	$ \Delta V_{1mA} / V_{1mA} \leq 10\%$ 无外观损伤															
8/20μs 电流冲击寿命试验	IEC 61051-1	8/20μs 电流波形，同方向冲击最大冲击电流 10 次(冲击电流对应 10 次的减额值)，间隔时间 30 秒。	$ \Delta V_{1mA} / V_{1mA} \leq 10\%$ 无外观损伤															
10/1000μs 电流冲击寿命试验	IEC 61051-1	10/1000μs 电流波形，同方向冲击最大冲击电流 10 次(冲击电流对应 10 次的减额值)，间隔时间 2 分钟。	$ \Delta V_{1mA} / V_{1mA} \leq 10\%$ 无外观损伤															
动作负载测试	UL 1449 3 rd	6KV/3KA 1.2/50μs+8/20μs 组合波耦合压敏电阻的最大连续交流工作电压，在 90° 相角上冲击 15 次，间隔 60 秒。 (适用于 UL1449 3rd SPD Type 3 application 测试)	$ \Delta V_p / V_p \leq 10\%$ 无外观损伤															
标称放电电流测试	UL 1449 3 rd	依照 UL 1449 3 rd 37.7 的测试条件，进行 3KA 8/20μs 电流波形冲击 15 次。 (适用于 TVR20R 系列 UL1449 3rd SPD Type2 application 测试)	$ \Delta V_p / V_p \leq 10\%$ 无外观损伤															
耐压试验	IEC 61051-1	金属球测试，2500 V _{ac} 1 分钟	无外观损伤															
压敏电压温度系数试验	规格标准	$\frac{V_{1mA@85^\circ\text{C}} - V_{1mA@25^\circ\text{C}}}{V_{1mA@25^\circ\text{C}}} \times \frac{1}{60} \times 100\% (\% / ^\circ\text{C})$ $\frac{V_{1mA@-40^\circ\text{C}} - V_{1mA@25^\circ\text{C}}}{V_{1mA@25^\circ\text{C}}} \times \frac{1}{65} \times 100\% (\% / ^\circ\text{C})$	-0.05 ≤ TC ≤ 0.05 (% / °C)															

氧化锌压敏电阻器：TVR-D 系列 浪涌保护用插件型(高能系列)



■ 包装

● 编带包装方式说明

S型 (直脚)



图 A



图 B

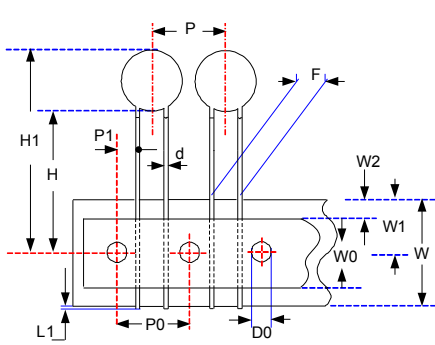

图 C

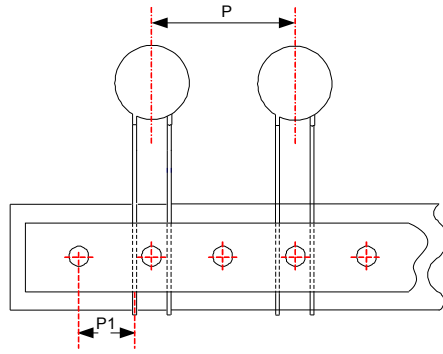

(单位: mm)

编带代码	系列	P ₀	F	P	P ₁	H	H ₁	d	W ₀	W ₁	W ₂	W	ΔP	Δh	L ₁	D ₀	T	图形
		±0.3	±1	±1	±0.7	+2/-0	Max.	±0.02	±1	+0.75/ -0.5	Max.	+1/ -0.5	Max.	Max.	Max.	±0.2	±0.2	
A (P ₀ : 12.7)	07-D	12.7	5.0	12.7	3.85	18	31	0.6	12	9	3	18	1	2	0.5	4	0.6	A
	10-D	12.7	7.5	25.4	8.95	18	36	0.8	12	9	3	18	1	2	0.5	4	0.6	B
	14-D	12.7	7.5	25.4	8.95	18	40	0.8	12	9	3	18	1	2	0.5	4	0.6	B
E (P ₀ : 15.0)	07-D	15.0	5.0	15.0	5.00	18	31	0.6	12	9	3	18	1	2	0.5	4	0.6	A
	10-D	15.0	7.5	15.0	3.75	18	36	0.8	12	9	3	18	1	2	0.5	4	0.6	A
	14-D	15.0	7.5	30.0	3.75	18	40	0.8	12	9	3	18	1	2	0.5	4	0.6	C

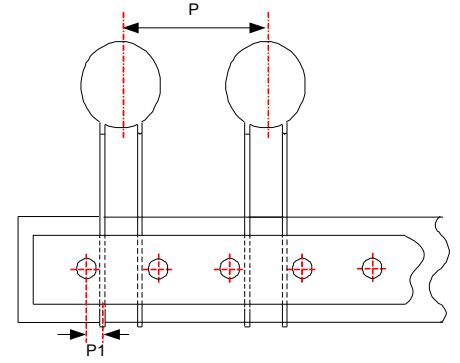
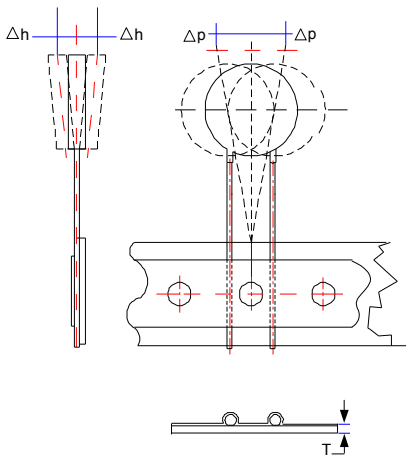
氧化锌压敏电阻器：TVR-D 系列 浪涌保护用插件型(高能系列)



F 型(Y 型引脚)



图 A



图 B

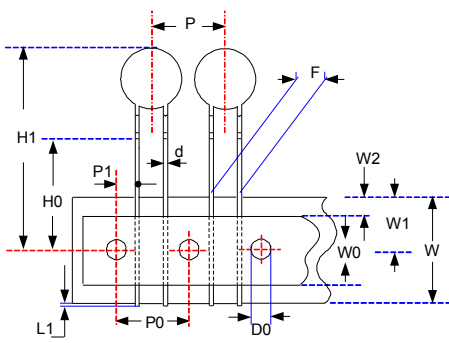

图 C

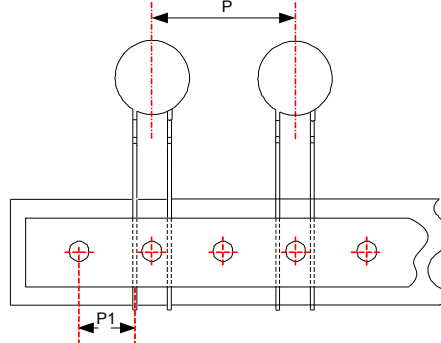

(单位: mm)

编带代码	系列	P ₀	F	P	P ₁	H ₀	H ₁	d	W ₀	W ₁	W ₂	W	ΔP	Δh	L ₁	D ₀	T	图形
		±0.3	±1	±1	±0.7	+2/-0	Max.	±0.02	±1	+0.75/-0.5	Max.	+1/-0.5	Max.	Max.	Max.	±0.2	±0.2	
A (P ₀ : 12.7)	07-D	12.7	5.0	12.7	3.85	16	31	0.6	12	9	3	18	1	2	0.5	4	0.6	A
	10-D	12.7	7.5	25.4	8.95	16	36	0.8	12	9	3	18	1	2	0.5	4	0.6	B
	14-D	12.7	7.5	25.4	8.95	16	40	0.8	12	9	3	18	1	2	0.5	4	0.6	B
E (P ₀ : 15.0)	07-D	15.0	5.0	15.0	5.00	16	31	0.6	12	9	3	18	1	2	0.5	4	0.6	A
	10-D	15.0	7.5	15.0	3.75	16	36	0.8	12	9	3	18	1	2	0.5	4	0.6	A
	14-D	15.0	7.5	30.0	3.75	16	40	0.8	12	9	3	18	1	2	0.5	4	0.6	C

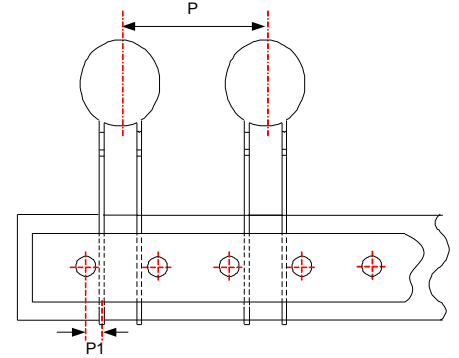
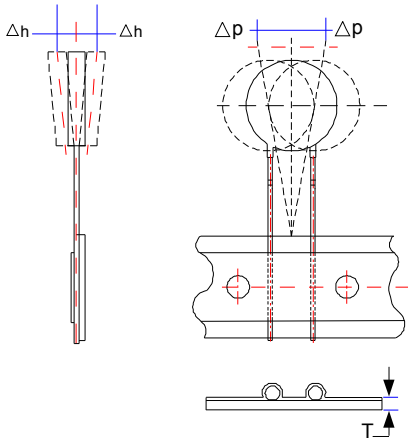
氧化锌压敏电阻器：TVR-D 系列

浪涌保护用插件型(高能系列)



数量

- 散装

系列	直脚型数量 (pcs/袋)	切脚型数量 (pcs/袋)	弯脚型数量 (pcs/袋)
TVR07-D	250	250	200
TVR10-D	200	200	200
TVR14-D	100	100	100
TVR20-D	50	50	50

- 卷轴包装

系列	A (mm)	数量 (pcs/卷)
TVR07(181~391) -D	46	1,500
TVR07(431~821) -D		1,000
TVR10(181~391) -D		1,000
TVR10 (431~561,681~911) -D		750
TVR10621-D		500
TVR10(102~112) -D		500
TVR14(181~331) -D	55	750
TVR14(361~112) -D		500
TVR20(181~681) -D		500
TVR20(751~112) -D		250

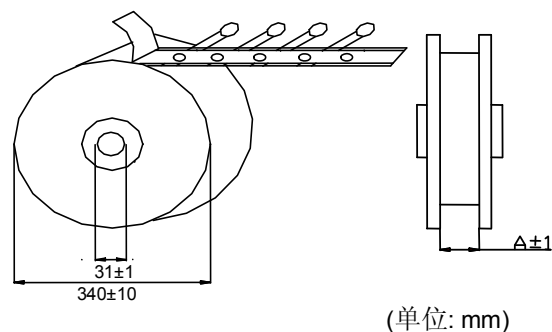

系列	数量 (pcs/盒)
TVR07(181~821) -D	1,000
TVR10(181~361) -D	750
TVR10(391~621) -D	400
TVR10(681~112) -D	300
TVR14(181~271) -D	500
TVR14(301~112) -D	250

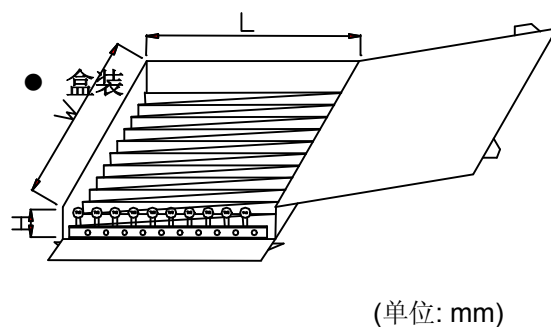

系列	W±5	L±5	H±5
TVR07-D~	348	185	60
TVR14-D	348	275	60

备注：TVR20-D 标准包装方式为散装，如有其它要求请联系销售人员。

仓库存储条件

- 存储条件：
 1. 储存温度：-10℃~+40℃
 2. 相对湿度：≤75%RH
 3. 不要将本产品存放在有腐蚀性气体或是阳光直接照射的环境中保管。
- 存储期限：1年